



# COMBINATION LOCKER LOCK

## AL-200L

*KSQ's The AL200 Combination Locker Lock Model is a budget-priced mechanical combination cam lock with Master override keys and code discovery feature.*

*Made from a high-quality matt-black ABS robust casing featuring black dials and large contrasting white numbers.*

*The AL200 features 3 wheel combination, with up to 1,000 possible combinations.*



### FEATURES & OPTIONS

- Mechanical digital combination cam lock
- Suit timber, plastic or metal lockers and doors
- Cam tongue operation with optional cams to suit sliding, offset, tambours
- 3 wheel combination dials with large white numbers on a black background
- Up to 1,000 possible combination codes
- Master override key for security and safety inspections (sold separately)
- Unknown code discovery feature for revealing the lock combination when unknown or forgotten
- In use indicators (Red locked/Green open)
- No batteries to change every couple of years
- Various straight and offset cams available.

**Lock Case Dimensions H50mm x W50mm x D18mm**

**Cylinder Lengths Model AL-200L 29mm Model AL-200S 14mm**

**Red "Locked" and Green "Unlocked" indicators for user friendly winged turn knob**

**19mm Double "Dee" door preparation for easy retrofit of existing key operated cam locks**

**Includes Secure Double "Dee" back-plate to prevent lock being rotated sideways to open**

**Available in 2 cylinder lengths to suit 15mm and 18mm timber doors**

**Includes Cam, Hex nut for timber doors and/or Spring clip for Metal locker installations**

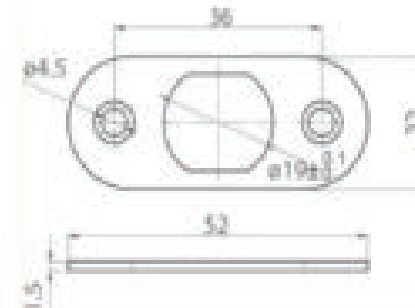
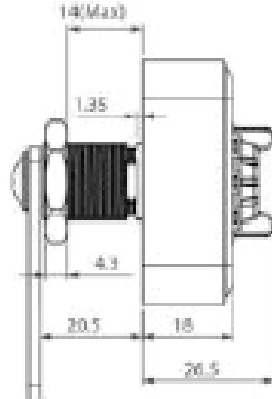
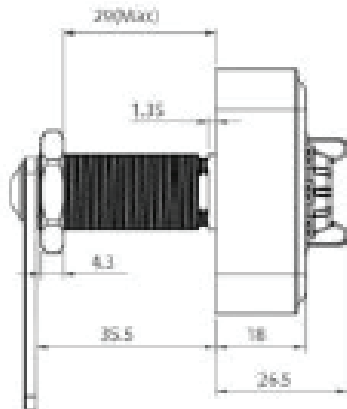

#### As Used For



Gyms



Cabinets



Schools



Mines



Hospitals



Universities



Offices



Libraries

November 2022

ABN 58668113595